

# ConnectX<sup>®</sup>-5 VPI Card

## 100Gb/s InfiniBand & Ethernet Adapter Card



Intelligent RDMA-enabled network adapter card with advanced application offload capabilities for High-Performance Computing, Web 2.0, Cloud and Storage platforms

ConnectX<sup>®</sup>-5 with Virtual Protocol Interconnect<sup>®</sup> supports two ports of 100Gb/s InfiniBand and Ethernet connectivity, sub-600ns latency, and very high message rate, plus PCIe switch and NVMe over Fabric offloads, providing the highest performance and most flexible solution for the most demanding applications and markets: Machine Learning, Data Analytics, and more.

### HPC Environments

ConnectX-5 delivers high bandwidth, low latency, and high computation efficiency for high performance, data intensive and scalable compute and storage platforms. ConnectX-5 offers enhancements to HPC infrastructures by providing MPI and SHMEM/PGAS and Rendezvous Tag Matching offload, hardware support for out-of-order RDMA Write and Read operations, as well as additional Network Atomic and PCIe Atomic operations support.

ConnectX-5 VPI utilizes both IBTA RDMA (Remote Direct Memory Access) and RoCE (RDMA over Converged Ethernet) technologies, delivering low-latency and high performance. ConnectX-5 enhances RDMA network capabilities by completing the Switch Adaptive-Routing capabilities and supporting data delivered out-of-order, while maintaining ordered completion semantics, providing multipath reliability and efficient support for all network topologies including DragonFly and DragonFly+.

ConnectX-5 also supports Burst Buffer offload for background checkpointing without interfering in the main CPU operations, and the innovative transport service Dynamic Connected Transport (DCT) to ensure extreme scalability for compute and storage systems.

### Storage Environments

NVMe storage devices are gaining popularity, offering very fast storage access. The evolving NVMe over Fabric (NVMe-oF) protocol leverages the RDMA connectivity for remote access. ConnectX-5 offers further enhancements by providing NVMe-oF target offloads, enabling very efficient NVMe storage access with no CPU intervention, and thus improved performance and lower latency.

Moreover, the embedded PCIe switch enables customers to build standalone storage or Machine Learning appliances. As with the earlier generations of ConnectX adapters, standard block and file access protocols can leverage RoCE for high-performance storage access. A consolidated compute and storage network achieves significant cost-performance advantages over multi-fabric networks.

## HIGHLIGHTS

### FEATURES

- Tag matching and rendezvous offloads
- Adaptive routing on reliable transport
- Burst buffer offloads for background checkpointing
- NVMe over Fabric (NVMe-oF) offloads
- Back-end switch elimination by host chaining
- Embedded PCIe switch
- Enhanced vSwitch/vRouter offloads
- Flexible pipeline
- RoCE for overlay networks
- PCIe Gen 4.0 support
- RoHS compliant
- ODCC compatible

### BENEFITS

- Up to 100Gb/s connectivity per port
- Industry-leading throughput, low latency, low CPU utilization and high message rate
- Innovative rack design for storage and Machine Learning based on Host Chaining technology
- Smart interconnect for x86, Power, Arm, and GPU-based compute and storage platforms
- Advanced storage capabilities including NVMe over Fabric offloads
- Intelligent network adapter supporting flexible pipeline programmability
- Cutting-edge performance in virtualized networks including Network Function Virtualization (NFV)
- Enabler for efficient service chaining capabilities
- Efficient I/O consolidation, lowering data center costs and complexity

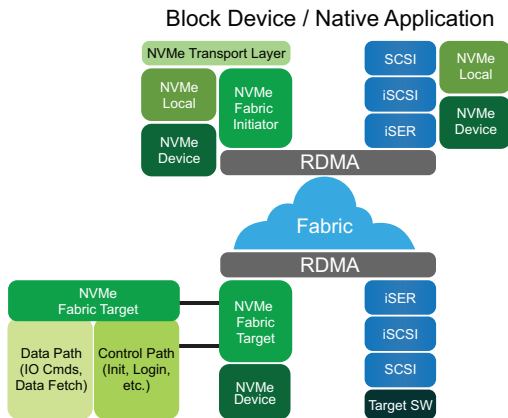

ConnectX-5 enables an innovative storage rack design, Host Chaining, by which different servers can interconnect directly without involving the Top of the Rack (ToR) switch.

With this new rack design alternative (Host Chaining), ConnectX-5 Socket Direct lowers the data center's Total Cost of Ownership (TCO) by reducing CAPEX (cables, NICs, and switch port expenses), and by reducing OPEX by cutting down on switch port management and overall power usage.

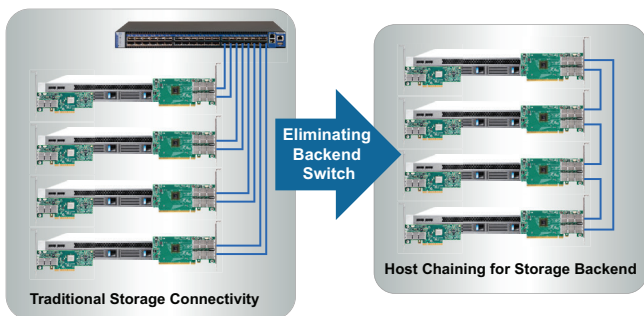

## Cloud and Web 2.0 Environments

Cloud and Web 2.0 customers that are developing their platforms on (Software Defined Network) SDN environments, are leveraging their servers' Operating System Virtual-Switching capabilities to enable maximum flexibility.

Open vSwitch (OVS) is an example of a virtual switch that allows Virtual Machines to communicate with each other and with the outside world. Virtual switch traditionally resides in the hypervisor and switching is based on twelve-tuple matching on flows. The virtual switch or virtual router software-based solution is CPU intensive, affecting system performance and preventing fully utilizing available bandwidth.

Mellanox's ASAP<sup>2</sup> - Accelerated Switching And Packet Processing<sup>®</sup> technology allows offloading the vSwitch/vRouter by handling the data plane in the NIC hardware, while maintaining the control plane unmodified. This results in significantly higher vSwitch/vRouter performance without the associated CPU load.

The vSwitch/vRouter offload functions that are supported by ConnectX-5 include Overlay Networks (for example, VXLAN, NVGRE, MPLS, GENEVE, and NSH) headers' encapsulation and de-encapsulation, as well as Stateless offloads of inner packets, packet headers' re-write enabling NAT functionality, and more.

Moreover, the intelligent ConnectX-5 flexible pipeline capabilities, which include flexible parser and flexible match-action tables, can be programmed, which enable hardware offloads for future protocols.

ConnectX-5 SR-IOV technology provides dedicated adapter resources and guaranteed isolation and protection for virtual machines (VMs) within the server. Moreover, with ConnectX-5 Network Function Virtualization (NFV), a VM can be used as a virtual appliance. With full data-path operations offloads as well as hairpin hardware capability and service chaining, data can be handled by the Virtual Appliance with minimum CPU utilization.

With these capabilities data center administrators benefit from better server utilization while reducing cost, power, and cable complexity, allowing more Virtual Appliances, Virtual Machines and more tenants on the same hardware.

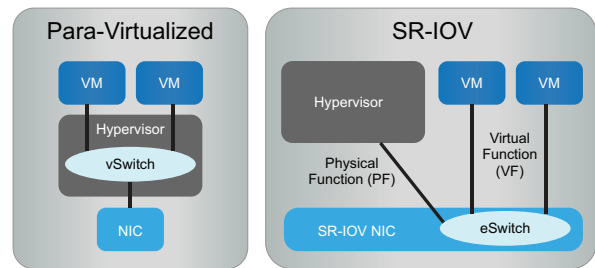

## Standard Host Management

Mellanox host management and control capabilities include NC-SI over MCTP over SMBus, and MCTP over PCIe - Baseboard Management Controller (BMC) interface, as well as PLDM for Monitor and Control DSP0248 and PLDM for Firmware Update DSP0267.

## Compatibility

### PCI Express Interface

- PCIe Gen 4.0, 3.0, 2.0 and 1.1 compatible
- 2.5, 5.0, 8, 16 GT/s link rate
- Auto-negotiates to x16, x8, x4, x2, or x1 lanes
- PCIe Atomic
- TLP (Transaction Layer Packet) Processing Hints (TPH)
- PCIe switch Downstream Port Containment (DPC) enablement for PCIe hot-plug

- Access Control Service (ACS) for peer-to-peer secure communication
- Advance Error Reporting (AER)
- Process Address Space ID (PASID) Address Translation Services (ATS)
- IBM CAPI v2 support (Coherent Accelerator Processor Interface)
- Support for MSI/MSI-X mechanisms

### Operating Systems/Distributions\*

- RHEL/CentOS
- Windows
- FreeBSD
- VMware
- OpenFabrics Enterprise Distribution (OFED)
- OpenFabrics Windows Distribution (WinOF-2)

*\*Refer to the driver and firmware release notes for OS availability.*

### Connectivity

- Interoperability with InfiniBand switches (up to EDR)
- Interoperability with Ethernet switches (up to 100GbE)
- Passive copper cable with ESD protection
- Powered connectors for optical and active cable support

## Features

*The section below describes hardware features and capabilities. Please refer to the driver and firmware release notes for feature availability.*

### InfiniBand

- EDR / FDR / QDR / DDR / SDR
- IBTA Specification 1.3 compliant
- RDMA, Send/Receive semantics
- Hardware-based congestion control
- Atomic operations
- 16 million I/O channels
- 256 to 4Kbyte MTU, 2Gbyte messages
- 8 virtual lanes + VL15

### Ethernet

- 100GbE / 50GbE / 40GbE / 25GbE / 10GbE / 1GbE
- IEEE 802.3bj, 802.3bm 100 Gigabit Ethernet
- IEEE 802.3by, Ethernet Consortium 25, 50 Gigabit Ethernet, supporting all FEC modes
- IEEE 802.3ba 40 Gigabit Ethernet
- IEEE 802.3ae 10 Gigabit Ethernet
- IEEE 802.3az Energy Efficient Ethernet (fast wake)
- IEEE 802.3ap based auto-negotiation and KR startup
- IEEE 802.3ad, 802.1AX Link Aggregation
- IEEE 802.1Q, 802.1P VLAN tags and priority
- IEEE 802.1Qau (QCN) – Congestion Notification
- IEEE 802.1Qaz (ETS)
- IEEE 802.1Qbb (PFC)
- IEEE 802.1Qbg
- IEEE 1588v2
- Jumbo frame support (9.6KB)

### Enhanced Features

- Hardware-based reliable transport
- Collective operations offloads
- Vector collective operations offloads
- Mellanox PeerDirect RDMA (aka GPUDirect®) communication acceleration
- 64/66 encoding
- Extended Reliable Connected transport (XRC)
- Dynamically Connected transport (DCT)
- Enhanced Atomic operations

- Advanced memory mapping support, allowing user mode registration and remapping of memory (UMR)
- On Demand Paging (ODP)
- MPI Tag Matching
- Rendezvous protocol offload
- Out-of-order RDMA supporting Adaptive Routing
- Burst buffer offload
- In-Network Memory registration-free RDMA memory access

### CPU Offloads

- RDMA over Converged Ethernet (RoCE)
- TCP/UDP/IP stateless offload
- LSO, LRO, checksum offload
- RSS (also on encapsulated packet), TSS, HDS, VLAN and MPLS tag insertion/stripping, Receive flow steering
- Data Plane Development Kit (DPDK) for kernel bypass applications
- Open vSwitch (OVS) offload using ASAP<sup>2</sup>
  - Flexible match-action flow tables
  - Tunneling encapsulation/de-capsulation
- Intelligent interrupt coalescence
- Header rewrite supporting hardware offload of NAT router

### Storage Offloads

- NVMe over Fabric offloads for target machine
- T10 DIF – Signature handover operation at wire speed, for ingress and egress traffic
- Storage protocols: SRP, iSER, NFS RDMA, SMB Direct, NVMe-oF

### Overlay Networks

- RoCE over Overlay Networks
- Stateless offloads for overlay network tunneling protocols
- Hardware offload of encapsulation and decapsulation of VXLAN, NVGRE, and GENEVE overlay networks

### Hardware-Based I/O Virtualization - Mellanox ASAP<sup>2</sup>

- Single Root IOV
- Address translation and protection
- VMware NetQueue support
  - SR-IOV: Up to 512 Virtual Functions
  - SR-IOV: Up to 8 Physical Functions per host
- Virtualization hierarchies (e.g., NPAR when enabled)
  - Virtualizing Physical Functions on a physical port
  - SR-IOV on every Physical Function
- Configurable and user-programmable QoS
- Guaranteed QoS for VMs

### HPC Software Libraries

- Open MPI, IBM PE, OSU MPI (MVAPICH/2), Intel MPI
- Platform MPI, UPC, Open SHMEM

### Management and Control

- NC-SI over MCTP over SMBus and NC-SI over MCTP over PCIe - Baseboard Management Controller interface
- PLDM for Monitor and Control DSP0248
- PLDM for Firmware Update DSP0267
- SDN management interface for managing the eSwitch
- I<sup>2</sup>C interface for device control and configuration
- General Purpose I/O pins
- SPI interface to flash
- JTAG IEEE 1149.1 and IEEE 1149.6

### Remote Boot

- Remote boot over InfiniBand
- Remote boot over Ethernet
- Remote boot over iSCSI
- Unified Extensible Firmware Interface (UEFI)
- Pre-execution Environment (PXE)

Table 1 - Part Numbers and Descriptions

OPN	Description	Dimensions w/o Bracket
MCX555A-ECAT	ConnectX <sup>®</sup> -5 VPI adapter card, FDR/EDR IB (100Gb/s) and 40/50/100GbE, single-port QSFP28, PCIe3.0 x16, tall bracket	14.2cm x 6.9cm (Low Profile)
MCX556A-ECAT	ConnectX <sup>®</sup> -5 VPI adapter card, FDR/EDR IB (100Gb/s) and 40/50/100GbE, dual-port QSFP28, PCIe3.0 x16, tall bracket	
MCX556A-ECUT	ConnectX <sup>®</sup> -5 VPI adapter card, FDR/EDR IB (100Gb/s) and 40/50/100GbE, dual-port QSFP28, PCIe3.0 x16, UEFI enabled, tall bracket	
MCX556A-EDAT	ConnectX <sup>®</sup> -5 Ex VPI adapter card, FDR/EDR IB (100Gb/s) and 40/50/100GbE, dual-port QSFP28, PCIe4.0 x16, tall bracket	

Note: All tall-bracket adapters are shipped with the tall bracket mounted and a short bracket as accessory.

Support: For information about our support packages, please contact your Mellanox Technologies sales representative or visit our [Support Index page](#).